

TOP VIEW

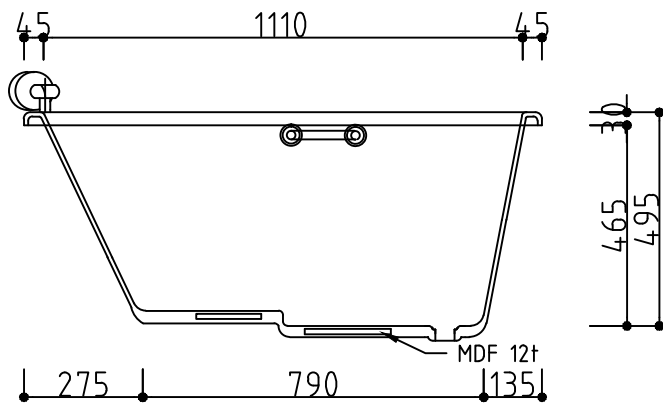

FRONT VIEW

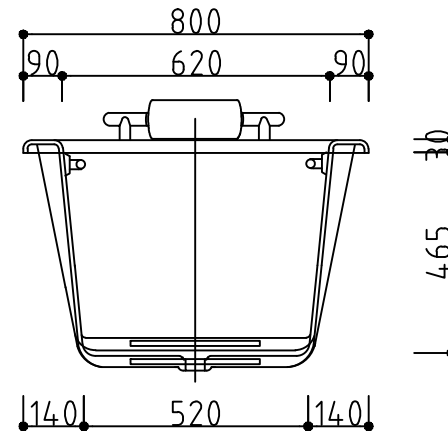

SIDE VIEW

■ PRODUCT NAME

BELLO

■ 본체 부품 설치 사양표

NO	품명	수량	비고
1	TUB BODY	1	유리섬유 강화고광택 아크릴(FRA)
2	MOTOR(1HP)	1	AQUAFLO(U.S.A)
3	EYEBALL-JET	2	AQUAFLO(U.S.A)
4	CONTROLLOR	1	AQUAFLO(U.S.A)
5	AIR-BUTTON	1	AQUAFLO(U.S.A)
6	OVER-FLOW DRAIN	1	FOOT-TOUCH SYSTEM

■ OPTION

NO	품명	수량	비고
1	HAND-BAR(SHORT)	2	
2	HEAD-REST	1	

NOTES	NO.	DATE	DESCRIPTION	PROJECT TITLE
				BELLO

Design	Scale	1/NON
Drawn	DATE	2003. 10. 20.
Checked	Drawing Title	BELLO
Approved	Drawing No.	Sheet No. L-01



interQua FACTORY
 625-1 SINNAM-RI DUNPO-MYOUN,
 AHSAN-SHI CHUNGNAM, SOUTH KOREA
 TEL : +82 - 41 - 531 - 7207.8
 FAX : +82 - 41 - 531 - 7209